

The Intelligent
Surveillance Solution



NVRsolo Quick Start Guide

Ver. 2.1.0.140521.00

Table of Contents

English	1
Hrvati	3
Čeština.....	5
Deutsch	7
Dansk	9
Français	11
Italiano	13
日本語.....	15
한국어.....	17
Norsk	19
Polski	21
Português.....	23
Русский	25
繁體中文.....	27
ភាសាខ្មែរ.....	29
Türkçe	31
Slovenščina	33
Español	35
Svenska.....	37
[Appendix] 1 bay unit deployment	39
[Appendix] 2 bay unit deployment.....	41

Step 1: Unpack the Unit

This package contains the following items:

	1bay Package	2bay Package	8bay Package
The unit	V	V	V
Remote control, 1.5M IR extender cable	V	V	V
Disk screws	V (for 2.5" and 3.5" disk)	V (for 3.5" disk)	V (for 3.5" disk)
Pad and stand	[Horizontal] foot pads; [Vertical] Stand, foot pads and screws	[Horizontal] foot pads; [Vertical] Stand, foot pads and screws	Foot pads
Power	12V 4A 48W power adapter, power cord	12V 5A 60W power adapter, power cord	Power cord
Warranty card, Quick Start Guide, CD	V	V	V
Rackmount kit, screws	-	-	V
Key	-	-	V*

* CD content: Install Wizard, Remote Live Viewer, Playback System, Backup System, Verification Tool and Offline License Tool application, user manual, and quick start guide

	Battery spec is 1.5V, AAA, R03. Two batteries are required for a remote control
---	---

Step 2: Install Hard Drives

Refer to compatibility list and install HDDs. For optimal performance consideration, install disks with the same model and storage capacity. The available RAID level depends on the amount of disks installed.

Step 3: Connect the Unit and Devices within the Network

Connect the unit, cameras, and router/switch. If you need to make the video visible over the Internet, please connect to a "router" with Internet connection, and the unit will retrieve an IP address through DHCP by default.

	The unit processes built-in DHCP service, which takes the job of router to assign IP addresses, which is suitable for the pure LAN environment.
---	---

Step 4: Connect the Monitor

The unit processes two display interfaces, VGA and HDMI. Connect the monitor to the unit.

	The supporting display resolutions are 1920x1080, 1280x1024, 1280x720, and 1024x768. Please confirm that one of the resolutions is supported by your monitor.
---	---

Step 5: Connect the Power

Press the power button once connecting the power.

Step 6: Set up the Unit

The Install Wizard guides you to initialize the system quickly.

1. When the system starts up, you have to choose the system language first. It takes a while for the system to restart.
2. After the system restarts, choose the initiation mode, and then click the Next button.



- Express Mode:** you don't need to set up the network and RAID level.
- Advanced Mode:** configure all settings manually: administrator password, network, license, camera, Date/Time, upgrade notification, and RAID level.

 If you are not familiar with network settings or not sure if your network includes a router, please connect all cables and cameras, and start with the Express mode.

3. Follow the directions of Install Wizard and click the FINISH button to start initializing.
4. After the initiation process ends, you can start to use the unit.



 We support configuration, liveview, and playback via web browser. (Internet Explorer11, Chrome on Windows OS, Safari on Mac OS)

Korak 1: Otpakirajte uređaj

U pakiranju se nalaze slijedeći dijelovi:

	1bay Package	2bay Package	8bay Package
Uređaj	✓	✓	✓
IC daljinski upravljač sa 1.5 m produžnog kabela	✓	✓	✓
Vijaka za 2.5"/3.5" tvrde diskove	✓ (2.5"/3.5")	✓ (3.5")	✓ (3.5")
Stalak, nožice i vijci	[Horizontalni] nožice; [Vertikalni] stalak, nožice i vijci	[Horizontalni] nožice; [Vertikalni] stalak, nožice i vijci	nožice i vijci
Napajački	12V 4A 48W napajački kabel i adapter	12V 5A 60W napajački kabel i adapter	kabel
Garancijaska kartica, CD za brzi start	✓	✓	✓
Rackmount kit, screws	-	-	✓
Key	-	-	✓

* CD sa instalacijskim čarobnjakom, Daljinski Live Viewer, Program za reprodukciju, sustav za Backup, Verifikacijski alat i alat za licenciranje bez pristupa internetu, korisnički priručnik i brzi vodič.



Baterije za daljinski upravljač su 1.5V, AAA, R03. Potrebne su dvije baterije.

Korak 2: Instalacija tvrdih diskova

Instalirajte tvrde diskove obrađujući pozornost na listu kompatibilnih tvrdih diskova. Za optimalne performanse upotrijebite diskove istog proizvođača i kapaciteta. Dostupan nivo RAID-a ovisi o broju instaliranih tvrdih diskova.

Korak 3: Spajanje uređaja na mrežu

Spojite uređaje (snimač, kamere, router/switch) na lokalnu mrežu. Ukoliko želite video učiniti dostupnim preko interneta, spojite se preko routera sa izlazom na internet, a snimaču će biti dodijeljena IP adresa preko DHCP protokola.



Uređaj ima ugrađen DHCP servis, koji preuzima dodjeljivanje IP adresa od routera. Ovo je pogodno za čisto LAN okruženje.

Korak 4: Spajanje monitora

Uređaj posjeduje dva sučelja, VGA i HDMI. Spojite monitor na uređaj



Podržane rezolucije su 1920x1080, 1280x1024, 1280x720, i 1024x768. Provjerite da li Vaš monitor podržava navedene rezolucije.

Korak 5: Spojite napajanje

Pritisnite tipku za paljenje nakon spajanja napajajućeg kabela.

Korak 6: Namještanje uređaja

Čarobnjak za instalaciju će Vas voditi kako bi ste brzo inicijalizirali sustav.

1. Kada se sustav pokrene, prvo izaberite sistemski jezik. Resetiranje sustava će potrajati neko vrijeme.
2. Nakon ponovnog pokretanja sustava izaberite Inicijalizaciju i kliknite na gumb Sljedeći.



- Ekspresni način:** nije potrebno namještavati mrežne I RAID postavke.
- Napredni način:** ručno konfiguriranje svih postavki: administratorskih lozinki, mreže, licence, kamere, datum/vrijeme, upozorenja za nadogradnju i RAID nivo.

 Ukoliko niste upoznati sa postavkama mreže ili niste sigurni da li u vašoj mreži postoji router, spojite sve kamere i pokrenite ekspresni način.

3. Pratite uputstva čarobnjaka za instalaciju i kliknite na Završetak za početak inicijalizacije.
4. Nakon procesa inicijalizacije Vaš uređaj je spreman za upotrebu.



 Konfiguracija, Živi prikaz, Pregled slike su podržani preko web preglednika (Internet Explorer 11, Mac Safari, Windows Chrome).

Krok 1: Rozbalte balení

Balení obsahuje následující:

	1 HDD verze	2 HDD verze	8 HDD verze
Zařízení	ANO	V	ANO
Dálkové ovládání, 1.5m IR Prodlužovací kabel	ANO	V	ANO
Šroubky na disky	ANO (pro 2.5" a 3.5" disky)	ANO (pro 3.5" disky)	ANO (pro 3.5" disky)
"Pad and stand"	[Horizontální] podložky na na nohy; [Vertikální] stojací, podložky na nohy a šroubky	[Horizontální] podložky na na nohy; [Vertikální] stojací, podložky na nohy a šroubky	Podložky na nohy
Napájení	12V 4A 48W napájecí adaptér, napájecí kabel	12V 5A 60W napájecí adaptér, napájecí kabel	Napájecí kabel
Záruční list, rychlý průvodce, CD	ANO	V	ANO
Rack montážní sada, šroubky	-	-	ANO
Klíč	-	-	ANO

* CD obsahuje: Install Wizard, Remote Live Viewer, Playback System, Backup System, Verification Tool a Offline License Tool, uživatelský manuál a rychlý průvodce

	Specifikace baterie je 1.5V, AAA, R03. Dálkové ovládání potřebuje 2 baterie.
--	--

Krok 2: Instalace harddisků

Zkontrolujte podporu harddisků a nainstalujte je. Pro optimální výkon instalujte harddisky stejného modelu a velikosti. Nastavitelná úroveň RAID je závislá na počtu harddisků v zařízení.

Krok 3: Připojení k síti

Připojte zařízení, kamery a router / switch. Pokud chcete sledovat video přes internet, tak připojte zařízení k routeru s přístupem na internet, zařízení poté dostane IP adresu pomocí DHCP.

	Zařízení zpracovává vestavěnou DHCP službu, která (na místo routeru) přiděluje IP adresy, vhodné pro čistě LAN prostředí.
---	---

Krok 4: Připojení monitoru

Zařízení podporuje 2 video výstupy, VGA a HDMI. Připojte monitor do zařízení.

	Podporovaná rozlišení jsou 1920 x 1080, 1280 x 1024, 1280 x 720 a 1024 x 768. Ujistěte se, že některé z těchto rozlišení je podporované vaším monitorem.
---	--

Krok 5: Připojení napájení

Po připojení k síti zařízení zapněte.

Krok 6: Nastavení zařízení

Install Wizard pro rychlou iniciaci systému.

1. Při spuštění systému si můžete vybrat jazyk. Poté se systém restartuje.
2. Po restartu systému vyberte režim iniciace a poté klikněte na tlačítko Další.



- Expresní režim**: nemusíte provádět síťové nastavení a nastavení RAIDu.
- Pokročilý režim**: všechna nastavení se provádí ručně: heslo administrátora, síťové nastavení, licence, nastavení kamer, nastavení datumu a času, nastavení automatického upozorňování na aktualizace a nastavení RAID.



Pokud nejste obeznámeni se síťovým nastavením nebo si nejste jistý, jestli se v síti nachází router, tak připojte vše chyň kabely a kamery a začněte v režimu Express.

3. Následujte pokyny Install Wizardu a klikněte na tlačítko Dokonceno pro začátek iniciace.
4. Po skončení iniciace můžete začít používat zařízení.

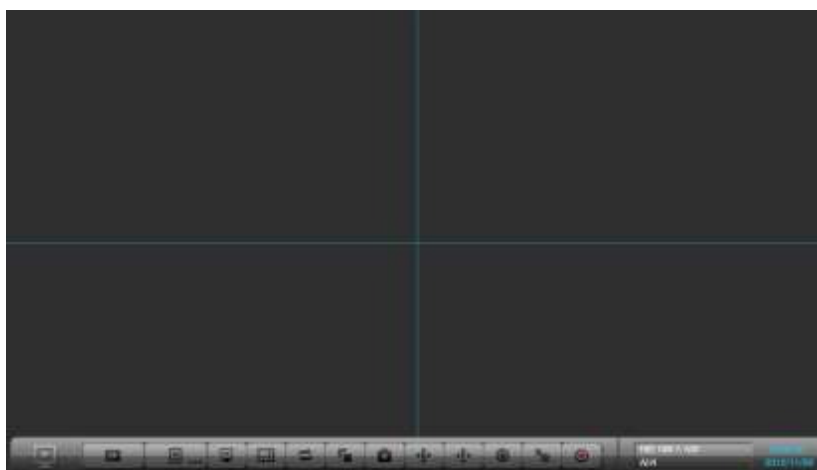

Podpora nastavení, živého zobrazení kamer a přehrávání přes webový prohlížeč přes webový prohlížeč. (Internet Explorer 11, Mac Safari, Windows Chrome)

Schritt 1: Gerät auspacken

Lieferumfang:

	1 bay Package	2 bay Package	8bay Package
Rekorder	V	V	V
IR-Fernbedienung, 1,50 m Verlängerungskabel	V	V	V
Schrauben für 2,5"/3,5" Laufwerke	V (2,5"/3,5")	V (3,5")	V (3,5")
Ständer und Standfüße	Für horizontalen Aufbau: Standfüße; für vertikalen Aufbau: Ständer, Standfüße und Schrauben	Für horizontalen Aufbau: Standfüße; für vertikalen Aufbau: Ständer, Standfüße und Schrauben	Standfüße
Netzteil, Netzkabel	12V 4A 48W Netzteil, Netzkabel	12V 5A 60W Netzteil, Netzkabel	Netzkabel
Garantiekarte, Kurzanleitung, CD	V	V	V
Rackmount kit, screws	-	-	V
Key	-	-	V

* CD mit: Installationsassistent, Remote Live Viewer, Playback-System, Backup-System, Überprüfungs-Tool und Offline Lizenz Tool, Bedienungsanleitung

	Batterie: 1,5 V, AAA, R03. Für die Fernbedienung sind zwei Batterien erforderlich.
--	--

Schritt 2: Laufwerke installieren

Zur Installation der Laufwerke lesen Sie bitte auch die Kompatibilitätsliste. Für eine möglichst optimale Leistung installieren Sie bitte Laufwerke des gleichen Modells und mit der gleichen Speicherkapazität. Der verfügbare RAID Level hängt von der Anzahl der installierten Laufwerke ab.

Schritt 3: Netzwerkverbindung herstellen

Schließen Sie den Rekorder, die Kameras und den Router/Switch an. Wenn Sie das Videobild übers Internet ansehen möchten, verwenden Sie bitte einen Router mit Internet-Verbindung, so dass eine IP-Adresse über DHCP standardmäßig erstellt wird.

	Der Rekorder verfügt über einen integrierten DHCP Service, der die Aufgabe eines Routers übernimmt, eine IP-Adresse zuzuweisen (für LAN-Umgebung geeignet).
---	---

Schritt 4: Monitor anschließen

Der Rekorder unterstützt VGA und HDMI. Schließen Sie den Monitor an den Rekorder an.

	Unterstützte Auflösungen: 1920x1080, 1280x1024, 1280x720 und 1024x768. Bitte stellen Sie sicher, dass Ihr Monitor eine dieser Auflösungen unterstützt.
---	--

Schritt 5: Gerät einschalten

Wenn Sie den Rekorder an die Stromversorgung angeschlossen haben, drücken Sie bitte die Power-Taste, um das Gerät einzuschalten.

Schritt 6: Rekorder einrichten

Der Installationsassistent ermöglicht Ihnen ein schnelles Einrichten des Systems.

1. Wenn das System startet, wählen Sie zuerst die Sprache aus. Es dauert einen Moment, bis das System neu startet.
2. Nach dem Neustart wählen Sie den Initialisierungsmodus und klicken auf nächstes.



- Express Modus:** Netzwerkeinstellungen und RAID Level sind nicht erforderlich.
- Erweiterter Modus:** Manuelle Konfiguration aller Einstellungen: Administrator-Passwort, Netzwerk, Lizenzen, Kamera, Datum/Uhrzeit, Upgrade-Benachrichtigungen und RAID Level.

	Falls Sie sich nicht sicher sein sollten, welche Netzwerk-Einstellungen Sie verwenden sollen oder ob Ihr Netzwerk einen Router einschließt, verbinden Sie bitte alle Kabel und Kameras und starten Sie den Express.
--	---

3. Befolgen Sie die Anweisungen des Installationsassistenten und klicken Sie auf Beenden, um die Initialisierung zu starten.
4. Nachdem die Initialisierung abgeschlossen ist, können Sie den Rekorder in Betrieb nehmen.

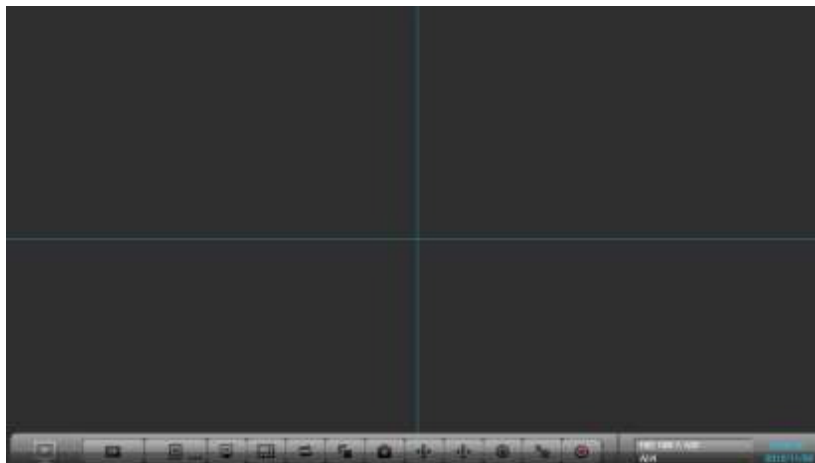

	Über den Web-Browser (Internet Explorer11, Mac Safari, Windows Chrome) werden Konfigurationen, Live-Ansicht und Wiedergabe unterstützt.
--	---

Trin 1: Udpakning af enheden

Denne pakke indeholder følgende elementer:

	1 bay Package	2 bay Package	8bay Package
Enheden	✓	✓	✓
IR fjernbetjening, 1.5M IR forlænger kabel	✓	✓	✓
Skruer til 2,5 "/ 3,5" harddiske	✓ (2,5 "/ 3,5")	✓ (3,5")	✓ (3,5")
Trædepuder, Stand	[Vandret] trædepuder, [Lodret] Stand, trædepuder og skruer	[Vandret] trædepuder, [Lodret] Stand, trædepuder og skruer	trædepuder
Strømforsyning	12V 4A 48W strømforsyning, ledning	12V 5A 60W strømforsyning, ledning	ledning
Garantibevis, Quick Start Guide, cd	✓	✓	✓
Rackmount kit, screws	-	-	✓
Key	-	-	✓

* cd med installations guiden, Live Viewer, Playback System, Backup System, Verifikation Værktøj og Offline Licens Værktøjs ansøgning, brugermanual, og hurtig start guide



Batteri spec er 1.5V, AAA, R03. To batterier er nødvendige til fjernbetjening.

Trin 2: Installer Harddiske

Se kompatibilitets liste og installere harddiske. For at opnå optimal ydeevne overvejelse, installere diske med samme model og lagerkapacitet. Det tilgængelige RAID niveau afhænger af mængden af installerede diske.

Trin 3: Tilslut enhed og enheder i netværket

Tilslut apparatet, kameraer, og router / switch. Hvis du har brug for at gøre videoen synlig over internettet, skal du oprette forbindelse til en "router" med internetforbindelse, og enheden vil hente en IP-adresse via DHCP som standard.



Enheden behandler indbygget DHCP tjenesten, som tager jobbet som router til at tildele IP-adresser, som er egnet til LAN miljø.

Trin 4: Tilslut skærmen

Enheden har to display udgange, VGA og HDMI. Tilslut skærmen til enheden.



Skærmopløsninger er 1920x1080, 1280x1024, 1280x720, og 1024x768. Bekræft venligst, at en af de opløsninger, er understøttet af din skærm.

Trin 5: Tilslut Strømmen

Tryk på afbryderknappen, når du tilslutter strømmen.

Trin 6: Opsætning af enheden

Installations Wizard guider dig, for at installere systemet hurtigt.

1. Når systemet starter op, er du nødt til at vælge dit system sprog først. Det tager et stykke tid før systemet genstarter.
2. Når systemet er genstartet, skal du vælge indledningens tilstand, og derefter klikke på knappen Næste.



- **Express Mode:** Du behøver ikke at opsætte netværket og RAID-niveau.
- **Avanceret Mode:** konfigurere alle indstillinger manuelt: administrator adgangs kode, netværk, licens, kamera, Dato / klokkeslæt, opgraderings meddelelse, og RAID niveau.



Hvis du ikke er bekendt med netværksindstillinger eller ikke sikker på, om dit netværk omfatter en router, skal du tilslutte alle kabler og kameraer, og start med Express Mode.

3. Følg anvisningerne i installationsguiden, og klik på knappen Afslut for at starte indledningen.
4. Efter indledningens processen slutter, kan du begynde at bruge enheden.

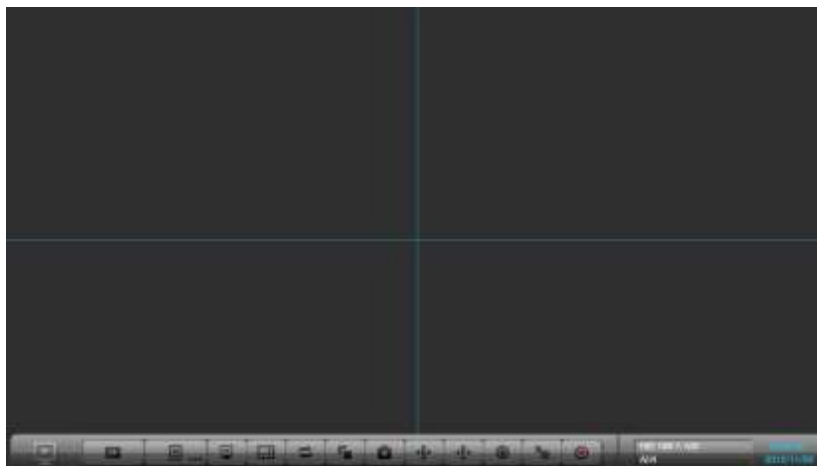

Understøttet konfiguration, LiveView, og afspilning via webbrowser. (Internet Explorer 11, Mac Safari, Windows Chrome)

Etape 1: Déballage de l'Unité

Ce paquet contient les éléments suivants:

	1 bay Package	2 bay Package	8bay Package
L'unité	V	V	V
Télécommande infrarouge, et câble d'extension 1.5M	V	V	V
vis pour les disques durs 2.5 et 3.5 pouces	V (2.5 et 3.5 pouces)	V (3.5 pouces)	V (3.5 pouces)
Piédestal et vis	V	V	V
Power	Adaptateur électrique 12V 4A 48W, cordon d'alimentation	Adaptateur électrique 12V 5A 60W, cordon d'alimentation	cordon d'alimentation
Carte de garantie, Guide de démarrage rapide, CD	V	V	V
Rackmount kit, screws	-	-	V
Key	-	-	V

* CD avec les logiciels Install Wizard, Remote Live Viewer, Playback System, Backup System, Verification Tool et Offline License Tool, manuel d'utilisateur et guide de démarrage rapide.

	Piles: 1.5V, AAA, R03. Deux piles sont requises pour le fonctionnement de la télécommande.
---	--

Etape 2: Installation des disques durs

Reportez-vous à la liste de compatibilité et installez les disques durs.

Pour obtenir des performances optimales, installez des disques durs identiques (même modèle et même capacité de stockage). Le niveau RAID disponible dépend du nombre de disques installés.

Step 3: Connectez l'Unité et les dispositifs au réseau

Connectez l'unité, les caméras et le router/switch (commutateur réseau). Si vous avez besoin de pouvoir visionner les vidéos par internet, merci de connecter un « router » disposant d'une connexion internet, l'unité disposera alors d'une adresse IP and the unit will retrieve an IP address through DHCP by default.

	L'unité dispose d'un service DHCP embarqué, qui remplace le router pour l'assignation d'une adresse IP. Cela est tout à fait utile dans un environnement LAN.
---	---

Step 4: Connectez l'Ecran

L'unité dispose de deux interfaces d'affichage, VGA et HDMI. Connectez l'écran à l'unité (une seule connexion simultanée possible).

	Les résolutions supportées d'affichage sont 1920x1080, 1280x1024, 1280x720, et 1024x768. Merci de vérifier que ces résolutions sont bien prises en charge par votre écran.
---	--

Step 5: Connectez l'Alimentation

Une fois connecté à l'alimentation, appuyez sur le bouton de mise en fonctionnement.

Step 6: Installer l'Unité

Le Wizard d'installation vous guide afin d'initialiser le système rapidement.

1. Lorsque que le système se lance, vous devez premièrement choisir le langage. Deuxièmement, laisser le système se réinitialiser.
2. Après redémarrage du système, choisissez un mode de lancement et cliquez sur le bouton Suivant.



- Mode Express:** vous n'avez pas besoin de définir le réseau ni le niveau RAID.
- Mode Avancé:** configurez tous les éléments manuellement: mot de passe administrateur, réseau, licence, caméras, date/heure, notification de mises à jour, et niveau RAID.

 Si vous n'êtes pas familier avec les paramètres des réseaux ou si vous n'êtes pas certain si votre réseau inclut un routeur, merci de connecter tous les câbles et caméras, et démarrez avec le mode Express.

3. Suivez les indications du Wizard d'installation et cliquez sur le bouton Terminer, afin de lancer l'initialisation.
4. Une fois l'initialisation terminée, vous pouvez commencer à utiliser l'unité.



 A travers le navigateur Internet (Internet Explorer 11, Mac Safari, Windows Chrome) vous pouvez effectuer la configuration, la Vue en Direct et la Relecture.

Step 1: Aprire la confezione

Questa confezione contiene:

	Confezione 1bay	Confezione 2bay	Confezione 8bay
L'unità NVR Solo	V	V	V
Telecomando, Cavo estensione 1.5M IR	V	V	V
Viti per dischi rigidi 2.5"/3.5"	V (Per dischi 2.5" e 3.5")	V (per dischi 3.5")	V (per dischi 3.5")
Piedini/Stand	[Orizzontale] piedini; [Verticale] Supporto, piedini e viti	[Orizzontale] piedini; [Verticale] Supporto, piedini e viti	Piedini
Alimentazione	Alimentatore 12V 4A 48W, cavo di alimentazione	Alimentatore 12V 5A 60W, cavo di alimentazione	Cavo di alimentazione
Scheda di garanzia, Guida rapida, CD	V	V	V
Kit Rackmount, Viti	-	-	V
Chiave	-	-	V

* Contenuto CD: Install Wizard, Remote Live Viewer, Sistema Playback, Sistema Backup, Strumento di verifica e Offline License Tool, manuale d'uso e guida rapida d'installazione.



Per il telecomando e' necessario usare 2 pile 1.5V, AAA, R03.

Step 2: Installazione dei dischi rigidi

Prima di installare gli HDD si prega di far riferimento all'elenco di compatibilita'. Per un rendimento ottimale si consiglia di installare dischi dello stesso modello e dimensioni. Il livello RAID dipende dal numero di dischi installati.

Step 3: Connessione dell'unita' e dispositivi nella rete locale

Connettere l'unita, le telecamere ed il router/switch. Se si ha bisogno di connessione ad Internet, si prega di connettersi ad un router con accesso Internet. L'unita ricevera per automaticamente un indirizzo IP via DHCP.



L'unita è dotata di un server DHCP integrato, che può fornire indirizzi IP automaticamente.

Step 4: Connessione del monitor

L'unita è dotata di due connettori display: VGA e HDMI. Connettere il monitor all'unita.



Le risoluzioni display supportate sono 1920x1080, 1280x1024, 1280x720, e 1024x768. Si prega di verificare prima che una di queste risoluzioni sia supportata dal monitor usato.

Step 5: Connettere l'alimentazione

Premere il pulsante d'alimentazione dopo aver connesso il cavo.

Step 6: Impostazioni dell'unità

L' Install Wizard spiega come inizializzare velocemente il sistema.

1. All'avvio si dovrà prima scegliere la lingua, poi attendere il riavvio del sistema
2. Dopo il riavvio del sistema, scegliere la modalità di inizializzazione, poi premere "Seguente"



- Modo Express:** Non richiede impostazioni di rete e RAID.
- Modo avanzato:** Configurazione manuale di tutte le impostazioni: Admin Password, rete, licenze, telecamere, data/ora, notifiche d'aggiornamento e livello RAID



Se non siete sicuri delle impostazioni di rete o si sapete se c'è un router nella rete, si prega connettere tutti i cavi e telecamere poi usare l'Express mode

3. Seguire le istruzioni dell'install wizard poi premere il pulsante "Finire" per riavviare.
4. Alla fine del processo di inizializzazione, l'unità è pronta all'uso.



Supporta configurazione, live view e playback usando Web browser (Internet Explorer 11, Mac Safari, Windows Chrome)

ステップ 1: 付属品の確認

製品の梱包内容は

	1bay パッケージ	2bay パッケージ	8bay パッケージ
本体	√	√	√
リモートコントロール, 1.5M IR 拡張用ケーブル	√	√	√
ハードディスク用ネジ	√ (2.5" と 3.5" ディスク)	√ (3.5" ディスク)	√ (3.5" ディスク)
パットとスタンド	[横] パット; [縦] スタンド, パットとネジ	[横] パット; [縦] スタンド, パットとネジ	パット
電源	12V 4A 48W 電源アダプター、電源コード	12V 5A 60W 電源アダプター、電源コード	電源コード
保証書, クイックスタートガイド, CD	√	√	√
ラックマウント、ネジ	-	-	√
鍵	-	-	√

* CD 内容: インストールウィザード, ライブビューアー, 再生ソフト, バックアップシステム, 検証ツール とオフラインツール, ユーザーマニュアル, とクイックスタートガイド

	電池のスペックは 1.5V, AAA, R03. リモートコントロールは二つの電池が必要です。
--	---

ステップ 2: ハードディスクのインストール

ハードディスク対応リストに載ってあるハードディスクをご使用ください。最高のパフォーマンスを実現するため、同じ型式、容量のハードディスクをインストールしてください。インストールするハードディスク台数により RAID レベルを利用可能です。

ステップ 3: ネットワークに接続する

本機、カメラ、ルーターやスイッチを接続してください。インターネットでビデオを見られるようにする場合、ルーターをインターネットに接続してください。機械はデフォルトで DHCP サーバーを通し、IP アドレスを取得します。

	NVRsolo は DHCP の機能を持ち、ルーターの代わりに IP アドレスを指定するので、単純な LAN 環境に適応します。
---	--

ステップ 4: モニターに接続する

NVRsolo は VGA と HDMI 二つのディスプレイインターフェイスがあります。モニターと機械を接続してください。

	解像度は 1920x1080, 1280x1024, 1280x720, と 1024x768 対応可能です。モニターが以上の解像度にサポートしていることを確認してください。
---	---

ステップ 5: 電源を接続する

電源を接続して電源ボタンを押してください。

ステップ 6: 本機をセットアップする

インストールウィザードに従って、セットアップが素早いできます。

1. システムを起動すると、まずシステム言語を選んでください。言語を選択するとシステムを再起動するので、少し時間がかかります。
2. システムを再起動すると、起動モードを選択し、次ボタンをクリックしてください。



- 高速モード**: ネットワークと RAID レベルを設定する必要はありません。
- 詳細モード**: 手動的にすべてのセッティングを設定します: 管理者パスワード, ネットワーク, ライセンス, カメラ, 日付/時間, 更新通知と RAID レベル。



ネットワーク設定、また、ネットワークでルーターが含まれることがわからない場合、全部のケーブルとカメラを接続して、**高速モード** を選んでください。

3. インストールウィザードの指示に従い、完了 ボタンをクリックして、初期化を実行します。
4. 初期化を終わりにになると、NVRsolo は使用可能になります

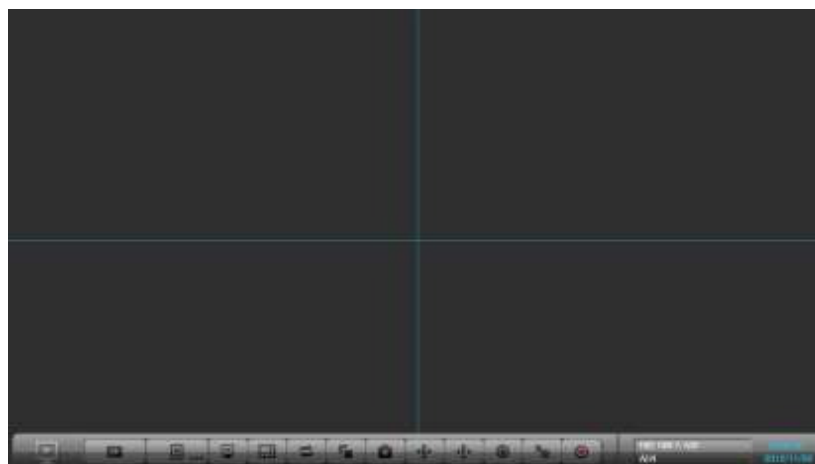

ブラウザー (Internet Explorer 11, Mac Safari, Windows Chrome) で設定、ライブビュー または再生の機能をサポートしています。

1 단계: 구성품

이 패키지는 다음과 같은 항목이 포함되어 있습니다.

	1 베이 패키지	8 베이 패키지	8 베이 패키지
장치	√	√	√
리모콘, 1.5M IR 확장 케이블	√	√	√
디스크 드라이브용 나사	√ (2.5" 디스크 및 3.5" 디스크용)	√ (3.5" 디스크)	√ (3.5" 디스크)
패드 및 스탠드	[가로] 풋패드; [세로] 스탠드, 풋패드, 나사	[가로] 풋패드; [세로] 스탠드, 풋패드, 나사	풋패드
전원	12V 4A 48W 전원 어댑터, 전원 코드	12V 5A 60W 전원 어댑터, 전원 코드	전원 코드
보증서, 간편 설명서, CD	√	√	√
랙마운트 키트, 나사	-	-	√
키	-	-	√

* CD 내용물: Install Wizard(설치 마법사), Remote Live Viewer(원격 라이브 뷰어), Playback System(재생 시스템), Backup System(백업 시스템), Verification Tool(검증 도구), Offline License Tool(오프라인 라이선스 도구) 애플리케이션, 사용자 설명서, 간편 설명서

	배터리 사양은 1.5V, AAA, R03 입니다. 리모콘은 2 개의 배터리가 필요합니다.
---	---

2 단계: 하드 드라이브 설치

호환성 목록을 참조하여 하드 디스크 드라이브를 설치하세요. 최적의 성능을 고려하여 동일한 모델 및 스토리지 용량으로 디스크를 설치하세요. 사용할 수 있는 RAID 레벨은 설치된 디스크 크기에 따라 달라집니다.

3 단계: 네트워크 내에서 장치 연결

장치, 카메라, 라우터/스위치 등을 연결하세요. 인터넷을 통해 비디오를 볼 수 있도록 하려면 "라우터"로 인터넷을 연결하세요. 기본적으로 장치는 DHCP를 통해 IP 주소를 검색합니다.

	이 장치는 순수 LAN 환경에 적합한 IP 주소를 할당하는 라우터의 작업을 하는 내장 DHCP 서비스를 처리할 수 있습니다.
---	---

4 단계: 모니터 연결

이 장치는 VGA 및 HDMI 등 2 개의 디스플레이 인터페이스를 가지고 있습니다. 모니터를 장치에 연결하세요.

	지원하는 디스플레이 해상도는 1920x1080, 1280x1024, 1280x720, 1024x768 등입니다. 위의 해상도 중 하나가 모니터에서 지원되는지 확인하세요.
---	--

5 단계: 전원 연결

전원을 연결 후 전원 버튼을 누르세요.

6 단계: 장치 설정

설치 마법사가 신속하게 시스템을 초기 설정하도록 안내합니다.

1. 시스템이 시작되면, 시스템 언어를 먼저 선택해야 합니다. 시스템이 재시작하는 데에 시간이 걸릴 수 있습니다.
2. 시스템을 다시 시작하면, 초기 모드를 선택한 다음 다음 버튼을 클릭하세요.



- 고속 모드:** 사용자가 네트워크 및 RAID 레벨 설정을 할 필요가 없습니다.
- 고급 모드:** 모든 설정을 수동으로 구성합니다. (관리자 암호, 네트워크, 라이선스, 카메라, 날짜/시간, 업데이트 알림, RAID 레벨 등)



네트워크 설정에 익숙하지 않거나 네트워크가 라우터를 포함하는지 확실하지 않으면, 모든 케이블 및 카메라를 연결하고 **Express mode(고속 모드)**를 선택하세요.

3. 설치 마법사의 지시에 따라 초기 설정을 시작하려면 종료 버튼을 클릭하세요.
4. 초기 설정이 모두 끝나면, 장치 사용을 시작할 수 있습니다.



구성, 라이브뷰, 재생 등을 웹 브라우저를 통해 지원합니다. (Internet Explorer 11, Mac Safari, Windows Chrome)

Steg 1: Pakk ut enheten

Denne pakken inneholder følgende:

	1bay Package	2bay Package	8bay Package
Selve enheten	V	V	V
IR fjernkontroll, 1.5M IR forlenger-kabel	V	V	V
Sruer for 2.5"/3.5" harddisker	V (2.5"/3.5")	V (3.5")	V (3.5")
Fot, pads	[Horisontal] pads; [Vertikal] fot, pads og skruer	[Horisontal] pads; [Vertikal] fot, pads og skruer	Pads
Power	12V 4A 48W spenningsadapter, strømkabel	12V 5A 60W spenningsadapter, strømkabel	strømkabel
Garantikort, Hurtigguide, CD	V	V	V
Rackmount kit, screws	-	-	V
Key	-	-	V

* CD med Install Wizard, Remote Live Viewer, Playback System, Backup System, Verification Tool og Offline License Tool applikasjon, brukermanual



Batterier til fjernkontrollen må være 1.5V, AAA, R03. To batterier kreves (medfølger ikke).

Steg 2: Installer harddisker

Se i referanselisten og installer diskene. For optimal virkemåte benytt diskene av samme modell og lagringskapasitet. Tilgjengelig RAID-nivå bestemmes av antall diskene som installeres.

Steg 3: Koble enheten og kameraer til nettverket

Koble opp enheten, kameraer og router/switch. Dersom du skal ha tilgang til enheten via internett må du koble deg til en router med internetttilgang, enheten vil hente en IP adresse via DHCP automatisk.



Enheden har innebygget DHCP service, som tar jobben til en router og gir IP adresser til kameraer, dette er gunstig for LAN oppsett.

Steg 4: Koble til monitoren

Enheden har to monitor interface, VGA og HDMI. Benytt ønsket terminal og koble til monitoren.



Enheden støtter display med en oppløsning på 1920x1080, 1280x1024, 1280x720, og 1024x768. Vennligst sjekk at din monitor støtter en av disse.

Steg 5: Starte opp enheten

Trykk på powerknappen for å starte opp enheten.

Steg 6: Konfigurere enheten

En hurtigguide "Install Wizard" vil hjelpe deg å sette opp systemet.

1. Når systemet starter må du først velge språk. Det vil ta en stund å restarte systemet etter dette.
2. Etter at systemet har startet opp på nytt, velg installasjonsmodus (Initiation Mode) og trykk på Next knappen.



- Express Mode:** du trenger ikke å sette opp nettverket eller RAID-nivå.
- Advanced Mode:** konfigurasjon av alle valg manuelt: administratorpassord, nettverk, lisens, kamera, dato/tid, oppgraderingsinformasjon og RAID-nivå.

	Dersom du ikke er kjent med nettverksoppsett eller ikke vet om ditt nettverk har en router, bør du benytte Express mode.
---	--

3. Følg meldingene som gis i oppsettsguiden (Install Wizard) og klikk på FINISH for å starte initieringen.
4. Etter at initieringen er ferdig, kan du bruke enheten.

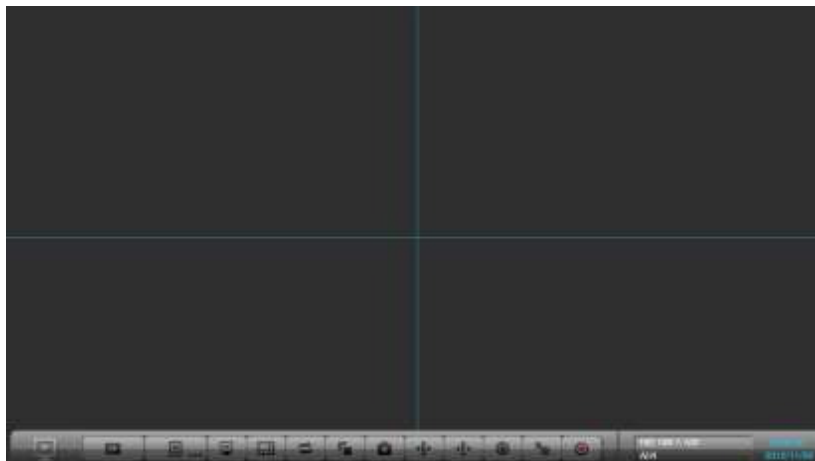

	Enheden støtter konfigurasjon, levende bilder, og avspilling via nettleser. (Internet Explorer 11, Mac Safari, Windows Chrome)
---	--

Krok 1: Rozpakuj Rejestrator

Paczka powinna zawierać następujące elementy:

	Rejestrator 1-dyskowy	Rejestrator 2-dyskowy	Rejestrator 8-dyskowy
Rejestrator	✓	✓	✓
Pilot zdalnego sterowania, 1.5m przewód czujnika IR	✓	✓	✓
Śrubki do dysków	✓ (dla 2.5" oraz 3.5" dysku)	✓ (dla 3.5" dysków)	✓ (dla 3.5" dysków)
Podstawka i stopki	[Poziomo] stopki; [Pionowo] podstawka, stopki oraz śrubki	[Poziomo] stopki; [Pionowo] podstawka, stopki oraz śrubki	Stopki
Zasilanie	Zasilacz 12V 4A 48W, przewód zasilający	Zasilacz 12V 5A 60W, przewód zasilający	Przewód zasilający
Karta Gwarancyjna, Szybki Przewodnik, CD	✓	✓	✓
Uchwyty do montażu RACK, śrubki	-	-	✓
Kluczyk	-	-	✓

* Zawartość CD: Install Wizard, Remote Live Viewer, Playback System, Backup System, Verification Tool oraz Offline License Tool, Instrukcja Użytkownika oraz Szybki Przewodnik

	Specyfikacja baterii: 1.5V, AAA, R03. Do pilota wymagane są dwie baterie.
--	---

Krok 2: Zainstaluj Dyski Twarde

Zainstaluj dyski zgodne z listą dysków kompatybilnych. W celu optymalizacji pracy rejestratora zalecana jest instalacja dysków tego samego modelu i pojemności. Dostępne poziomy RAID zależne są od ilości zainstalowanych dysków.

Krok 3: Podłącz Rejestrator i Urządzenia do sieci komputerowej

Podłącz Rejestrator, Kamery oraz Router/Switch. Jeżeli chcesz uzyskać dostęp do rejestratora poprzez sieć Internet należy podłączyć Rejestrator do sieci z dostępem do sieci Internet. Domyślnie w Rejestratorze włączone jest automatyczne pozyskiwanie adresu IP z serwera DHCP.

	Urządzenie posiada wbudowany serwer DHCP, co pozwala w sieciach bez podłączenia do Internetu na automatyczne przypisywanie adresów IP urządzeniom w sieci tj. kamery.
---	---

Krok 4: Podłącz monitor

Rejestrator wyposażony jest w dwa wyjścia graficzne, VGA oraz HDMI. Podłącz monitor do Rejestratora.

	Obsługiwane rozdzielczości to: 1920x1080, 1280x1024, 1280x720 oraz 1024x768. Upewnij się, że Twój monitor obsługuje co najmniej jedną z tych rozdzielczości.
---	--

Krok 5: Podłącz zasilanie

Po podłączeniu Rejestratora do zasilania wciśnij przycisk Power.

Krok 6: Konfiguracja Rejestratora

Oprogramowania Kreator Instalacji (Install Wizard) przeprowadzi Cię przez proces inicjalizacji systemu.

1. Podczas uruchamiania systemu należy wybrać język menu. Należy odczekać chwilę, aż system ponownie się uruchomi.
2. Po uruchomieniu systemu, wybierz tryb inicjalizacji i naciśnij przycisk **Następny**.



- Tryb Ekspresowy**: nie jest wymagana konfiguracja sieci oraz RAID.
- Tryb Zaawansowany**: ręczna konfiguracja wszystkich ustawień: hasło administratora, sieć, licencje, kamery, Data/ Czas, powiadamianie o aktualizacjach oraz RAID.



Jeżeli nie znasz ustawień sieci lub nie wiesz, czy w sieci istnieje jakiś serwer DHCP, podłącz wszystkie przewody oraz kamery i wybierz Tryb Ekspresowy.

3. Postępuj zgodnie ze wskazówkami Kreatora Instalacji i naciśnij przycisk **Zakończ**, aby rozpocząć inicjalizację systemu.
4. Po zakończeniu procesu inicjalizacji można rozpocząć korzystanie z Rejestratora.



Przez przeglądarkę Internet Explorer 8 lub wyższą można uzyskać dostęp do konfiguracji, podglądu na żywo oraz odtwarzania. (Internet Explorer 11, Mac Safari, Windows Chrome)

Passo 1: Desempacotando a unidade

Este pacote contém os seguintes itens:

	Pacote de 1 baia	Pacote de 2 baia	Pacote de 8 baias
A unidade	V	V	V
Controle Remoto I. Vermelho, cabo extensor de 1,5 m	V	V	V
Parafusos p/o HD	V (para HD 2.5" e 3.5")	V (para HD 3.5")	V (para HD 3.5")
Suporte e pés	[Horizontal] pés autocolantes; [Vertical] suporte, pés e parafusos	[Horizontal] pés autocolantes; [Vertical] suporte, pés e parafusos	Pés autocolantes.
Fonte de alimentação	Adaptador 12V 4A 48W, e cabo	Adaptador 12V 5A 60W, e cabo	cabo
Cartão de garantia, Guia Rápido, CD*	V	V	V
Kit montagem rack, parafusos	-	-	V
Chave	-	-	V

* Conteúdo do CD: Assistente de Instalação, Client Remoto Live Viewer, Client de Playback, Sistema de Backup, Ferramenta de marca d'água e Ferramenta de Licença Offline, manual e guia de instalação rápida.



Baterias de 1,5 V, tipo AAA, R03. Duas baterias são necessárias para o controle remoto.

Passo 2: Instale o(s) HD(s)

Favor verificar a lista de compatibilidade e então instalar o(s) HD(s). Para consideração de ótima performance, instale discos idênticos (mesmo fabricante, modelo e capacidade de armazenamento). O nível RAID disponível para configuração dependerá do número de discos instalados.

Passo 3: Conectar a unidade e os dispositivos dentro da rede ethernet

Conectar a unidade, câmeras, e o roteador / switch. Se for necessário disponibilizar vídeo através da Internet, favor conectar à um roteador com acesso à mesma, e a unidade irá adotar um IP válido via DHCP, por padrão de fábrica.



A unidade possui um serviço DHCP próprio, que executa o trabalho de um roteador para assinalar os IPs de dispositivos na rede, o que é apropriado para ambientes de rede LAN pura.

Passo 4: Conectar o Monitor

A unidade processa duas interfaces de monitor, VGA e HDMI. Conectar o monitor à unidade.



As resoluções de monitor suportadas são: 1920x1080, 1280x1024, 1280x720, e 1024x768. Favor confirmar que seu monitor suporte uma destas resoluções, antes de conectá-lo.

Passo 5: Conectar a fonte (energia)

Pressione o botão Power depois de conectar a unidade à fonte e à tomada.

Passo 6: Configurar a unidade

O assistente de instalação o guiará para inicializar rapidamente a unidade.

1. Quando o sistema iniciar, você deverá escolher, primeiramente, o idioma de sua preferência. Levará um pequeno período de tempo para a unidade reinicializar.
2. Após a reinicialização do sistema, escolher o modo de inicialização, e então clicar no botão **Próximo**.



- Modo Expresso**: você não precisa configurar os parâmetros de rede, nem o nível RAID.
- Modo Avançado**: configurar todos parâmetros manualmente: senha de administrador, rede, licença, câmeras, Data/Hora, notificação de upgrade, e nível RAID.

 Se você não está familiarizado com configurações de rede, ou não têm certeza se sua rede possui um roteador, favor conectar todos os cabos e cameras, e inicie pelo Modo Expresso.

3. Siga as diretrizes do Assistente de Instalação e clique no botão **Finalizar** para proceder a inicialização.
4. Após o processo de inicialização, você poderá utilizar a unidade.

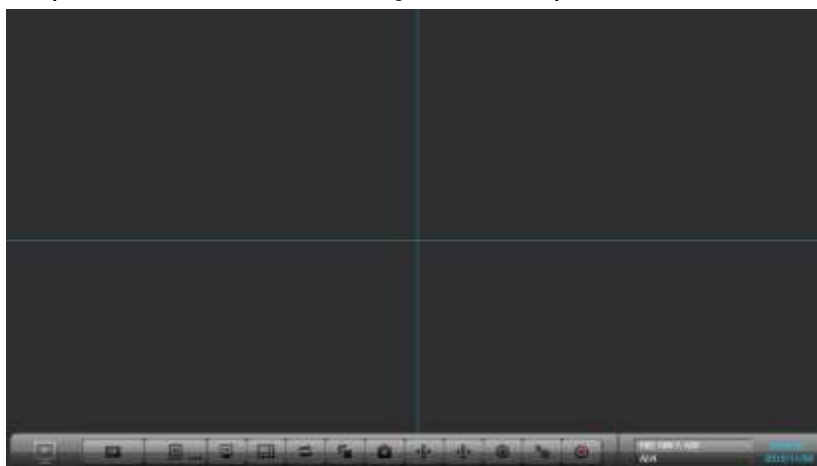

 Configuração, Vídeo ao Vivo e Playback são suportados via Cliente Navegador de Internet - Browser (Internet Explorer11, Mac Safari, Windows Chrome).

Шаг 1: Распаковать устройство

В комплект поставки входит:

	Упаковка 1 отсека	Упаковка 2 отсека	Упаковка 8 отсеков
Устройство	✓	✓	✓
Пульт управления, удлинитель ИК (1.5 м)	✓	✓	✓
Болты	✓ (для 2.5" и 3.5" жестких дисков)	✓ (для 3.5" жесткого диска)	✓ (для 3.5" жесткого диска)
Подставка и ножки	[Горизонтальное] foot pads; [Vertical] Stand, foot pads and screws	[Горизонтальное] foot pads; [Vertical] Stand, foot pads and screws	Ножки
Блок питания	Адаптер и шнур питания на 12В 4А 48Вт	Адаптер и шнур питания на 12В 4А 48Вт	Шнур питания
Гарантийная карта, Краткое руководство для начала работы, диск	✓	✓	✓
Крепления для стойки, болты	-	-	✓
Ключ	-	-	✓

* Диск включает: Install Wizard (мастер установки), Remote Live Viewer (просмотр), Playback System (воспроизведение), Backup System (резерв), Verification Tool (проверка подлинности) и Offline License Tool (офлайн активация лицензии), user manual (руководство пользователя), and quick start guide (краткое руководство для начала работы).



Спецификация батарейки 1.5V, AAA, R03. Для пульта управления необходимы 2 батарейки.

Шаг 2: Установить жесткие диски

Сверьтесь со списком совместимых жестких дисков и установить их. Для получения оптимальной производительности устанавливайте диски одной модели и одинаковой емкости. Доступный уровень RAID зависит от количества установленных дисков.

Шаг 3: Подключиться к сети

Подключите устройство, камеры и маршрутизатор/коммутатор. Если Вам необходимо просматривать видео через Интернет, пожалуйста, подключитесь к маршрутизатору со связью с Интернетом, и устройство получит IP адрес посредством DHCP.



Устройство имеет встроенный DHCP сервер, который раздаст IP адреса внутри локальной сети.

Шаг 4: Подключить монитор

Возможно подключение мониторов как VGA, так и HDMI соединением к устройству.



Поддерживаемые разрешения: 1920x1080, 1280x1024, 1280x720, и 1024x768. Пожалуйста, проверьте, чтобы Ваш монитор поддерживал одно из этих разрешений.

Шаг 5: Подключить питание

После подключения к источнику питания, нажмите кнопку включения питания.

Шаг 6: Установить параметры устройства

Установка параметров осуществляется с помощью Установщика.

1. При начале работы системы, Вам необходимо выбрать язык. После чего система перезагрузится.
2. После перезагрузки системы, Вам необходимо выбрать режим установки и нажать кнопку **Дальше**.

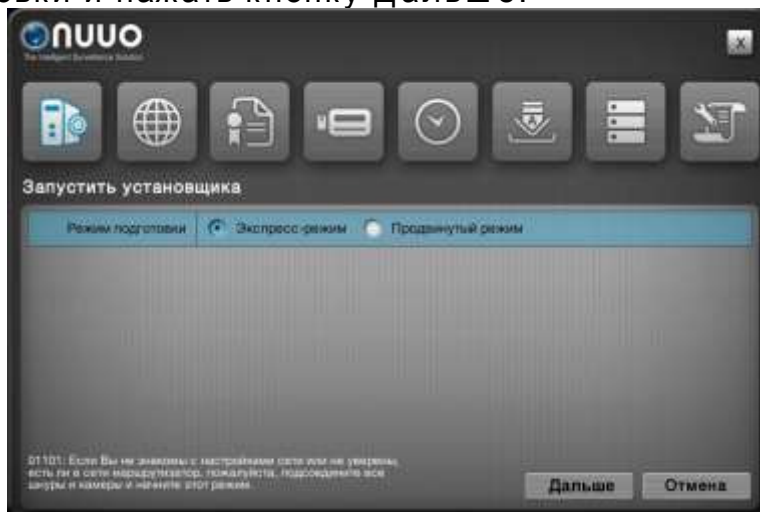

- Экспресс-режим**: в этом режиме не требуется делать установки сети и уровня RAID.
- Продвинутый режим**: все настройки делаются вручную: настройки пароля администратора, сети, лицензии, камер, даты и времени, уведомлений об обновлении и уровня RAID.

 Если Вы не можете самостоятельно сделать настройки сети или Вам неизвестно, есть ли в сети маршрутизатор, пожалуйста, подключите все кабели и камеры и выберите Экспресс режим.

3. Следуйте указаниям Установщика, нажмите кнопку **Закончить** для запуска системы.
4. После процесса запуска, Вы можете начать работу.

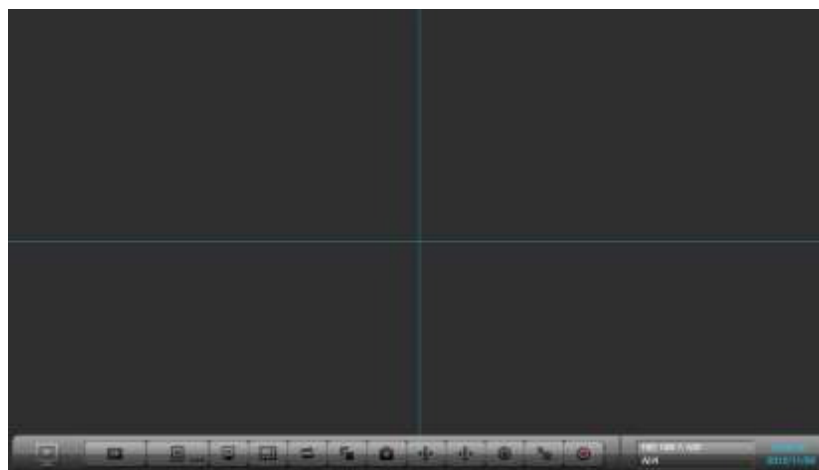

 Устройство поддерживает настройки, просмотр и воспроизведение в режиме веб-браузера (Internet Explorer 11, Mac Safari, Windows Chrome)

步驟一：打開包裝

本包裝中含有下列物品：

	1bay 包裝	2bay 包裝	8bay 包裝
主機	√	√	√
紅外線遙控器、1.5 公尺 紅外線接收遙控線	√	√	√
硬碟用螺絲包	√ (2.5 吋和 3.5 吋硬碟用)	√ (3.5 吋硬碟用)	√ (3.5 吋硬碟用)
繖墊和腳座	[橫躺式] 腳墊; [直立 式] 腳座、腳墊及螺絲	[橫躺式] 腳墊; [直立 式] 腳座、腳墊及螺絲	腳墊
電源	12V 4A 48W 電源變壓 器、電源線	12V 5A 60W 電源變壓 器、電源線	電源線
保固卡、快速安裝手 冊、CD 光碟	√	√	√
耳架、螺絲	-	-	√
前面板鎖頭板手	-	-	√

* CD 內容: Install Wizard (安裝精靈), Remote Live Viewer (即時影像), Playback System (回放系統), Backup System (備份系統), Verification Tool (驗證工具) and Offline License Tool (離線啟動序號工具) 等應用程式、使用手冊及快速安裝手冊

	電池規格是 1.5V, AAA, R03 (碳鋅電池), 一支遙控器需要兩顆電池。
---	---

步驟二：安裝磁碟機

請參考相容性表選擇合適的硬碟。為獲得最佳效能，請安裝同一型號與容量的硬碟；依照放置的硬碟數量決定本裝置內磁碟機可選擇的磁碟陣列(RAID)組合

步驟三：連接本機及相關裝置至網路

連接本機、攝影機、路由器/交換器。如果你需要透過網際網路看到影像，請使用連接網路的路由器，以自動分配 IP 至本機及相關裝置。

	本機具內建 DHCP 伺服器服務，可取代路由器分配 IP 給其他裝置，適合純區域網路的環境使用。
---	--

步驟四：連接螢幕

本機具有兩個顯示界面，VGA 和 HDMI。連接螢幕至本機。

	目前支援的螢幕解析度為 1920x1080、1280x1024、1280x720 及 1024x768。請確認你的螢幕支援任一解析度。
---	---

步驟五：連接電源

連接電源線及變壓器並插入電源插座後，按下機身上的電源按鈕。

步驟六：設定裝置

使用安裝精靈執行本裝置的設定程序以快速初始。

1. 當系統啟動時，請先選擇系統語言。系統需要一小段時間重啟生效。
2. 當系統重啟後，請選擇初始模式，並按下一步。



- 快速模式**：無須設定網路及 RAID 層級。
- 進階模式**：必須設定所有設定，包括管理者密碼變更、網路、序號、攝影機、日期/時間、更新通知及 RAID 層級。



如果你對網路設定不太熟悉，或者不確定網路環境是否已經路由器，請在接好所有線路及攝影機後，點選此模式開始進行初始化。

3. 依照安裝精靈的指示一步步完成設定，完成最後一個設定步驟後按下**結束**按鈕開始執行初始化。
4. 待初始化結束後，你便可以開始使用本機了。

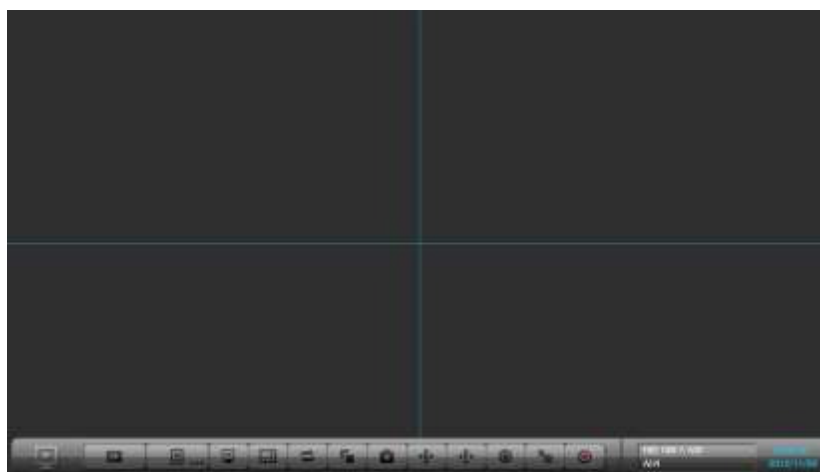

本機支援透過 web 瀏覽器作設定、瀏覽即時影像、回放。(Internet Explorer 11, Mac Safari, Windows Chrome)

ขั้นตอนที่1: เปิดกล่องสินค้า

ประกอบด้วยรายการต่อไปนี้:

	ชุดซีดี (1 bay)	ชุดซีดี (2bay)	ชุดซีดี (8bay)
ตัวเครื่อง (Unit)	V	V	V
รีโมทคอนโทรลพร้อมสาย 1.5M	V	V	V
สกรูสำหรับยึดฮาร์ดดิสก์	V(สำหรับ ฮาร์ดดิสก์ ขนาด25' และ 35')	V(สำหรับฮาร์ดดิสก์ขนาด 35')	V(สำหรับฮาร์ดดิสก์ขนาด 35')
ฐานรองเครื่อง (Pad and stand)	[แฉกตั้ง] ฐานรองที่พืด pads; [แฉกตั้ง] ฐานรองแฉกตั้งและสกรู	[แฉกตั้ง] ฐานรองที่พืด pads; [แฉกตั้ง] ฐานรองแฉกตั้งและสกรู	ฐานรองที่พืด
แหล่งจ่ายไฟ	อะแดปเตอร์ 12V4A48W สายไฟ	อะแดปเตอร์ 12V5A60W สายไฟ	สายไฟ
แผ่นประกบกันสินค้า, วิธีตั้งค่าแบบรวดเร็ว,แผ่น CD	V	V	V
ชุด Packmount , สกรู	-	-	V
กุญแจ (Key)	-	-	V

*แผ่นCDจะมี : Install Wizard, Remote Live Viewer, Playback System, Backup System, Verification Tool และ Offline License Tool application, คู่มือการใช้งาน, และวิธีตั้งค่าแบบรวดเร็ว

	แบตเตอรี่ขนาด 1.5V, AAA FOB จำนวน2'กอนสำหรับรีโมทคอนโทรล
---	--

ขั้นตอนที่2 ติดตั้งฮาร์ดดิสก์

อ้างอิงรายการฮาร์ดดิสก์ที่แนะนำ สมกับใช้งานและการติดตั้ง เพื่อให้ผลการทงานได้มีประสิทธิภาพควรติดตั้งฮาร์ดดิสก์รุ่นและความจุที่เหมือนกัน การทง PAD จะขึ้นอยู่กับภาณฮาร์ดดิสก์ที่ติดตั้ง

ขั้นตอนที่3 เชื่อมต่อเครื่องและอุปกรณ์กับเน็ตเวิร์ค

เชื่อมต่อเครื่อง, ก้ลองและ เราท์เตอร์/สวิตซ์ ถ้าคุณต้องการดูภาพอินเตอร์เน็ต ต้องเชื่อมต่อเราท์เตอร์และสัญญาณอินเตอร์เน็ต และเครื่องจะทงการดึงไอดีแอดเดรสทง DHCP โดยใส่ค่าเริ่มต้น

	หน่วยประมวลผลในตัวมีการ DHCPซึ่งใช้เวลาทงงานของเราเตอร์เพื่อกาหนดไอดีพีซึ่งเหมาะสำหรับสภาพแวดล้อม LANจริงๆ
---	--

ขั้นตอนที่4: ตรวจสอบภาพ

ตัวเครื่องสามารถเชื่อมต่อับจอภาพได้2แบบคือ VGAและ HDMI ทงการต่อจอภาพกับตัวเครื่อง



ความละเอียดการแสดงผลที่รองรับคือ 1920x1080, 1280x1024, 1280x720, and 1024x768,
 หมายเหตุ: ความละเอียดของจอภาพของคุณตรงกับความละเอียดของตัวเครื่องที่รองรับ.

ขั้นตอนที่ 5: ต่อสายการจ่ายกำลังไฟ

กดปุ่มเปิดการทำงานของหลังจากต่อการจ่ายกำลังไฟ

ขั้นตอนที่ 6: ตั้งค่าเครื่องฯ

ติดตั้งโปรแกรมช่วย (Wizard) และดำเนินการเริ่มต้นระบบอย่างรวดเร็ว .

1. เมื่อระบบเริ่มทำงาน คุณต้องเลือกภาษาก่อน ในเวลาที่คุณสกรีนเริ่มต้นทำงานใหม่
2. หลังจากนั้นเลือกขั้นตอนเริ่มต้นและคลิกปุ่มถัดไป (next button)



- Express Mode:** เมื่อคุณไม่ต้องการทำการตั้งค่าเน็ตเวิร์คและการเลือก PWD
- Advanced Mode:** เมื่อคุณต้องการกำหนดค่าด้วยตนเอง เช่น รหัสผ่านผู้บริหาร (administrator password), เน็ตเวิร์ค (network), license, กาลัง, วันเวลา, การแจ้งเตือนการปรับปรุง, การเลือก PWD



ถ้าคุณไม่แน่ใจในการเลือกการตั้งค่าเน็ตเวิร์ค หรือเน็ตเวิร์ค รวมถึงเราท์เตอร์, เมื่อต่อสายที่หมดแล้วให้เลือกขั้นตอนรวดเร็ว (Express Mode)

3. ทอดานขั้นตอนของการโปรแกรมช่วย Wizard และคลิกปุ่มสิ้นสุด (FINSH) เพื่อเริ่มการทำงานเบื้องต้น
4. หลังจากดำเนินการเสร็จแล้ว คุณสามารถเริ่มการใช้งานเครื่องฯ

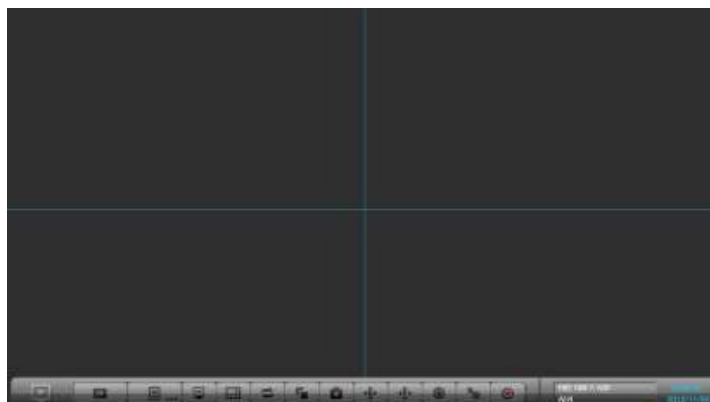

เราขอรับการสนับสนุน liveview และ playback ผ่าน web browser (Internet Explorer 11, Mac Safari, Windows Chrome)

Adım 1: Cihazı Açın

Bu paket aşağıdaki öğeleri içermektedir:

	1 bölmeli Paket	2 bölmeli Paket	8 bölmeli paket
Cihaz	✓	✓	✓
Uzaktan kumanda, 1.5M IR Uzatma kablosu	✓	✓	✓
2.5"/3.5" disk sürücüler için 2 tür vida	V (2.5"/3.5")	V (3.5")	V (3.5")
Ayaklık, ayak tabanları	[Yatay] ayak tabanları; [Dikey] Ayaklık, ayak tabanları ve vidalar	[Yatay] ayak tabanları; [Dikey] Ayaklık, ayak tabanları ve vidalar	Ayak tabanları
güç	12V 4A 48W güç adaptörü, güç kablosu	12V 5A 48W güç adaptörü, güç kablosu	güç kablosu
Garanti belgesi, Hızlı başlangıç, CD	✓	✓	✓
Rackmount kiti, vidalar	-	-	✓
Anahtar	-	-	✓

* CD ile Kurulum Sihirbazı, Uzaktan Canlı İzleme, Playback Sistemi, Yedekleme Sistemi, Doğrulama Aracı ve Çevrimdışı License Araç uygulaması, manual kullanım, ve hızlı başlangıç klavuzları

	Pil özelliği 1.5V, AAA, R03 dir. 2 adet pil uzaktan kumanda cihazı için gereklidir.
---	---

Adım 2: Sabit Disk Yükleme

Uyumluluk listesine bakınız ve HDD disklerini kurunuz. En iyi performans değerlendirmesi için, diskleri aynı model ve depolama kapasiteleri ile kurunuz. Mevcut RAID seviyesi yüklenen disk miktarına bağlıdır.

Adım 3: Cihazı Bağlama ve Cihazları Ağ' a Bağlama

Cihazı, kameraları ve router/switch cihazlarını bağlayınız. İnternet üzerinden video izlemek istiyorsanız, internet bağlantısı olan router cihazı bağlayınız. Cihaz varsayılan DHCP üzerinden IP alacaktır.

	Cihaz, dahili DHCP servisi içererek, ağ ortamınıza uygun olarak router üzerinden IP adres almanızı sağlar.
---	--

Adım 4: Monitör Bağlantısı

Cihaz VGA ve HDMI olmak üzere 2 ekran arayüzüne sahiptir. Monitörü cihaza bağlayınız.

	Desteklenen ekran çözünürlükleri 1920x1080, 1280x1024, 1280x720, ve 1024x768 dir. Lütfen monitörünüzün desteklediği çözünürlüğü ayarlayınız.
---	--

Adım 5: Güç Bağlantısı

Gücü bağlamak için Power tuşuna basınız.

Adım 6: Cihazı Kurma

Yükleme Sihirbazı sisteme hızlı başlatmak için size yol gösterecektir.

1. Sistem başladığında öncelikle sistem dilini seçmeniz gerekmektedir. Sistemi yeniden başlatmak biraz süre alacaktır.
2. Sistem yeniden başladıktan sonra, başlatma modunu seçiniz ve ardından Next (ileri) tuşuna basınız.



- Express Mode** Ağ ve RAID seviyesi kurmaya gerek yoktur.
- Advanced Mode (Gelişmiş Mod)**: Tüm ayarlar manuel olarak yüklenir. Yönetim şifresi, ağ, lisans, kamera, tarih/zaman, güncelleme bildirimi, RAID seviyesi.



Ağ ayarlarınız hakkında bilgi sahibi değilseniz yada ağınızda router cihazı olup olmadığını bilmiyorsanız, lütfen tüm kablo, kameraları bağlayınız ve Express modunu başlatınız.

3. Yüklemeye Sihirbazı ve işlemlerini izleyin ve başlatmak için FINISH tuşuna basınız.
4. Başlatma işlemi tamamlandıktan sonra, cihazı başlatınız.



İnternet üzerinden yapılandırma, Canlı izleme, ve playback için Internet Explorer 8 ve üzeri önerilir. (Internet Explorer 11, Mac Safari, Windows Chrome)

Korak 1: Odpakirajte napravo

V paketu se nahajajo nasledni deli:

	1bay Package	2bay Package	8bay Package
snemalnik	V	V	V
IR daljinski upravljalnik, IR podaljšek s kablom 1.5m	V	V	V
vijakov za 2.5"/3.5" trde diske	V (2.5"/3.5")	V (3.5")	V (3.5")
Pad and stand	[Horizontal] foot pads; [Vertical] Stand, foot pads and screws	[Horizontal] foot pads; [Vertical] Stand, foot pads and screws	Foot pads
napajalnik	12V, 4A, 48W napajalnik s priključnim kablom	12V, 5A, 48W napajalnik s priključnim kablom	priključnim kablom
Garancijaski list, Hitri vodnik, CD	V	V	V
Rackmount kit, screws	-	-	V
Key	-	-	V

* CD za inštalacijo in čarovnikom za pomoč, Program za spremljanje v Živo, Program za pregled Arhiva, Sistem za prenos Arhiva, Verifikacijsko orodje in orodje za licenciranje bez pristopa interneta, navodila.

	Baterije za daljinski upravljalnik so 1.5V, AAA, R03. Potrebna sta dva kosa.
---	--

Korak 2: Namestitev trdih diskov

Namestite diske, ki so navedni v listi kompatibilnosti. Za optimalno delovanje uporabite diske istega proizvajalca in z enako velikostjo. Nivo RAID-a je odvisen od števila uporabljenih diskov.

Korak 3: Povezovanje na omrežje

Povežite naprave (snemalnik, kamere, switch) na interno omrežje. V kolikor želite dostop preko interneta se povežite na Usmerjevalnik (Router), ki ima dostop do interneta. Snemalnik bo prejel IP naslov preko DHCP protokola.

	Snemalnik ima vgrajen DHCP servis za prevzemanje IP naslova z routerja.
---	---

Korak 4: Priklop monitorja

Snemalnik ima dva izhoda, VGA i HDMI. Priklopite monitor na izbran izhod.

	Podprte resolucije so 1920x1080, 1280x1024, 1280x720, in 1024x768. Preverite, če vaš monitor podpira navedene resolucije.
---	---

Korak 5: Priključite napajanje

Ko ste povezali napajalni kabel in vse ostalo, pritisnite tipko za vklop naprave.

Korak 6: Nastavljanje snemalnika

Spremljal vas bo vodnik (Wizard) za hitrejše in lažje nastavljanje.

1. Ko se sistem požene izberite jezik namestitve. Sistem se ponovno zažene, to traja nekaj časa.
2. Po ponovnem zagonu izberite inicijacijski način. Nato izberite Naprej



- Ekspresni način:** Ni potrebno nastavljanje mreže in RAID polja.
- Napredni način:** Ročno nastavljanje vseh parametrov: administracijska gesla, mreže, licence, kamere, datum/čas, načini posodabljanja in RAID nivo.



V kolikor niste poznavalec mreže ali ne veste, če je sistem priklopljen na router, uporabite Ekspresni način.

3. Spremljajte navodila pomočnika in na koncu izberite Zaključni, začela se bo namestitvev.
4. Po zaključku namestitve je vaš snemalnik pripravljen za uporabo.



Nastavljanje, Živi prikaz, Pregled arhiva so podprti preko web brskalnika (Internet Explorer 11, Mac Safari, Windows Chrome)

Paso 1: Desempaquetar la unidad

Este paquete contiene los siguientes elementos:

	Paquete de 1bay	Paquete de 2bay	Paquete de 8bay
La unidad	✓	✓	✓
Control remoto IR, 1.5M IR cable de extensión	✓	✓	✓
Tornillos para discos	V (para disco de 2.5" y 3.5")	V (para disco de 3.5")	V (para disco de 3.5")
Patas de goma y parado	[Horizontal] patas de goma; [Vertical] Parado, patas de goma y tornillos	[Horizontal] patas de goma; [Vertical] Parado, patas de goma y tornillos	Patas de goma
Adaptador de corriente	Adaptador de corriente 12V 4A 48W, cable de alimentación	Adaptador de corriente 12V 5A 60W, cable de alimentación	cable de alimentación
Tarjeta de garantía, Guía Rápida de Inicio, CD	✓	✓	✓
Kit de montaje raqueable, tornillos	-	-	✓
Llave	-	-	✓

* Contenido del CD: Asistente de Instalación, Live Viewer Remoto, Sistema Playback, Sistema Backup, Herramienta de Verificación y Aplicación Herramienta de Licencia Offline, manual de usuario y guía rápida de inicio



La especificación de la batería es 1.5V, AAA, R03. Dos baterías son necesarios para un control remoto.

Paso 2: Instalación de Discos Duros

Consulte la lista de compatibilidad e instale las unidades de disco duro. Para la consideración de un rendimiento óptimo, instale con el mismo modelo de disco y capacidad de almacenamiento. El nivel de RAID disponible depende de la cantidad de discos instalados.

Paso 3: Conecte las Unidades y Dispositivos a la Red

Conecte la unidad, cámaras, y router/switch. Si usted necesita hacer el video visible a través de Internet, conecte a un "router" con conexión a Internet, y la unidad recuperará una dirección IP mediante DHCP por defecto.



La unidad procesa incorporado el servicio DHCP, que toma el trabajo de router para asignar direcciones IP, lo que es adecuado para el puro ambiente LAN.

Paso 4: Conecte el Monitor

La unidad procesa dos interfaces de pantalla, VGA y HDMI. Conecte el monitor a la unidad.



Las resoluciones de soporte de pantalla son 1920x1080, 1280x1024, 1280x720 y 1024x768. Favor de confirmar que una de las resoluciones es soportada por su monitor.

Paso 5: Conexión a la Fuente de Alimentación

Pulse el botón para encender una vez que se conecte a la fuente de alimentación.

Paso 6: Instalar la Unidad

El asistente de instalación le guiará para iniciar el sistema rápidamente.

1. Cuando el sistema se inicia, tiene que elegir en primer lugar el idioma del sistema. Toma un tiempo para que el sistema se reinicie.
2. Una vez reiniciado el sistema, seleccione el modo de inicio, a continuación, haga clic en el botón Siguiente.



- Modo Express:** no es necesario configurar la red y el nivel de RAID.
- Modo Avanzado:** configura todos los ajustes manualmente: contraseña de administrador, red, licencia, cámara, fecha/hora, notificación de actualización, y el nivel de RAID.



Si usted no está familiarizado con la configuración de red o no está seguro de si la red incluye un router, conecte todos los cables y cámaras, y comience con el modo Express.

3. Siga las instrucciones del asistente de instalación y haga clic en el botón Terminado para empezar a inicializar.
4. Después de que el proceso de inicio termine, usted puede comenzar a utilizar la unidad.



Soportamos la configuración, liveview y playback a través del navegador web. (Internet Explorer 11, Mac Safari, Windows Chrome)

Step 1: Packa upp enheten

Innehåll i förpackningen:

	1bay Package	1bay Package	8bay Package
Enheten	V	V	V
Fjärrkontroll, 1.5M IR förlängningskabel	V	V	V
Skruvar för 2.5"/3.5" hårddiskar	V (2.5"/3.5")	V (3.5")	V (3.5")
Foot pads, Hållare	[Horisontal] foot pads; [Vertikal] Hållare, foot pads och skruvar	[Horisontal] foot pads; [Vertikal] Hållare, foot pads och skruvar	Foot pads
Power	12V 4A 48W strömadapter och sladd	12V 4A 48W strömadapter och sladd	sladd
Garanti kort, Snabbstartsguide, CD	V	V	V
Rackmount kit, screws	-	-	V
Key	-	-	V

* CD med Install Wizard, Remote Live Viewer, Playback System, Backup System, Verification Tool och Offline License Tool application och användar manual.

	Battery spec är 1.5V, AAA, R03. Två batterier behövs till fjärrkontrollen.
---	--

Step 2: Installera Hårddisk

Kontrollera med kompatibilitets listan och installera hårddisk. För bästa prestanda, installera hårddiskar med samma storlek och prestanda. Tillgängliga RAID konfigurationer beror på antalet diskar som installerats.

Step 3: Anslut enheten och annan utrustning i nätverket

Anslut enheten, kameror, och router/switch. Om du vill göra video tillgänglig över internet, anslut enheten till en Internet uppkopplad router så kommer den att få en IP adress via DHCP default.

	The unit processes built-in DHCP service, which takes the job of router to assign IP addresses, which is suitable for the pure LAN environment.
---	---

Step 4: Connect the Monitor

The unit processes two display interfaces, VGA and HDMI. Connect the monitor to the unit.

	Supporterade display upplösningar är 1920x1080, 1280x1024, 1280x720, and 1024x768. Kontrollera att din monitor stödjer någon av dessa upplösningar.
---	---

Step 5: Anslut strömmen

Tryck på Power knappen när du anslutit strömmen.

Step 6: Ställa in enheten

Installations guiden hjälper dig att få igång systemet snabbt.

1. När systemet startats upp behöver du först välja språk. Det tar sedan en stund för systemet att startas om.
2. Efter omstart, Välj initierings läge och klicka på Nästa.



- Express läge:** Du behöver inte ställa in nätverk och RAID konfiguration
- Avancerat läge:** Gör alla inställningar manuellt: administrators lösenord, nätverk, licens, kamera, Datu/Tid, uppdaterings notifieringar och RAID.



Om du är osäker på nätverksinställningar eller om det finns en router i nätverket, anslut alla kablar och kameror och starta med express läge.

3. Följ stegen i installations guiden och klicka på Klar knappen för att starta initieringen.
4. Efter att initierings processen är klar kan du börja använda enheten.



Vi stödjer configuration, live och uppspelning via WEB läsare. (Internet Explorer 11, Mac Safari, Windows Chrome).

[Appendix] 1 bay unit deployment

Horizontal

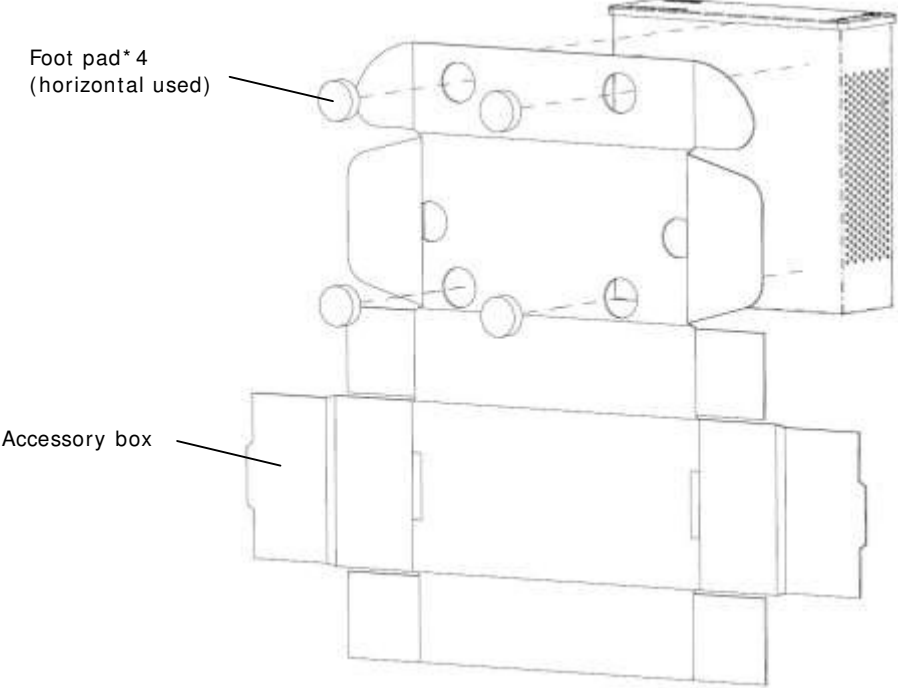

Vertical

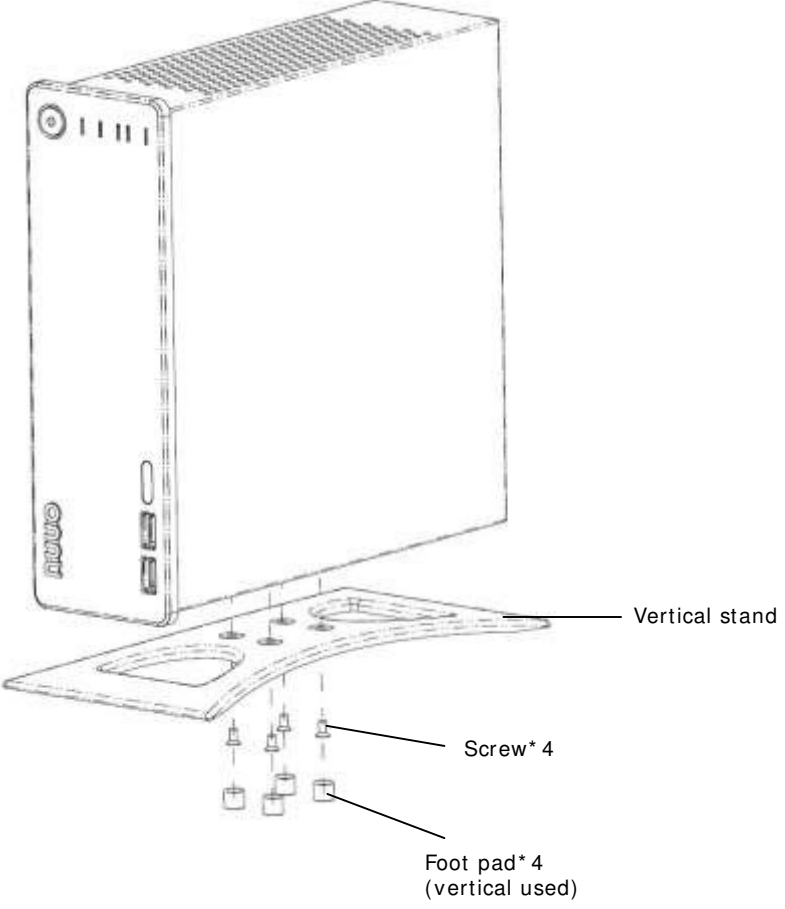

Install 3.5" HDD

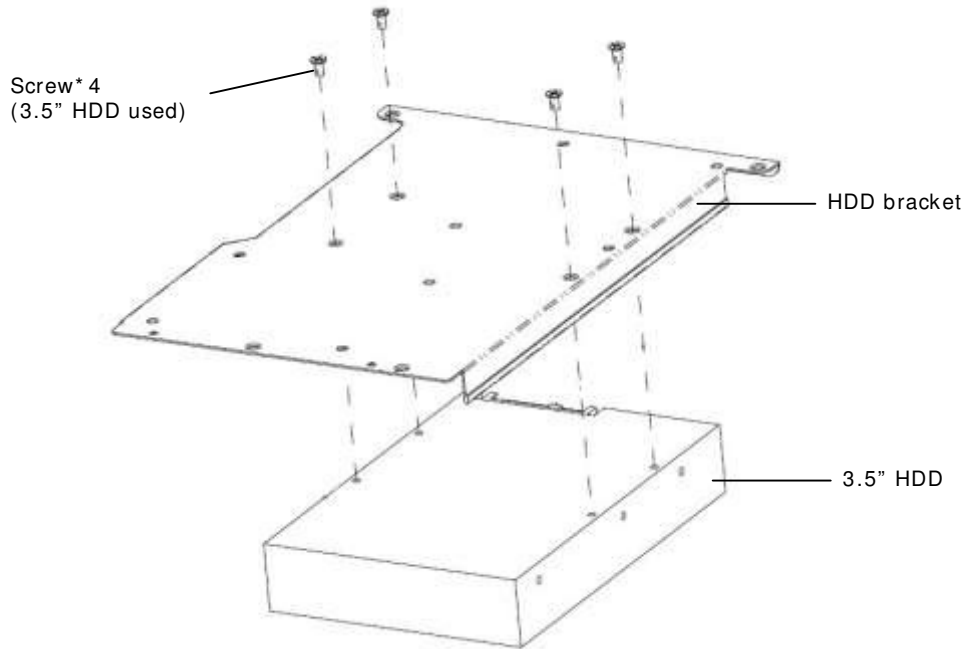

Install 2.5" HDD

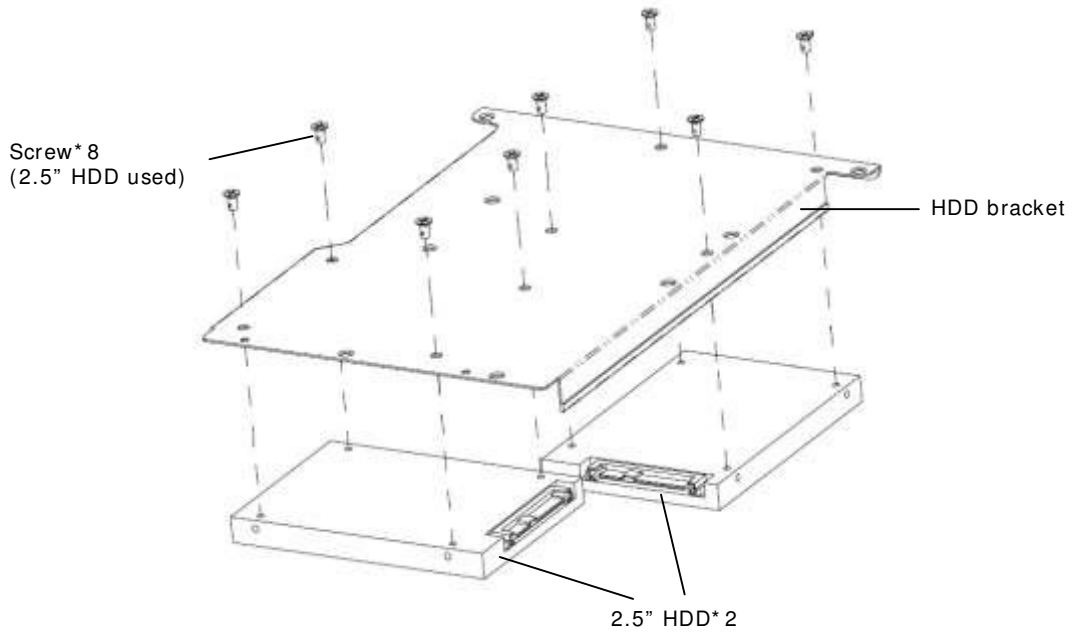

When installing HDDs on HDD bracket, please mind your hands from scratching.

[Appendix] 2 bay unit deployment

Horizontal

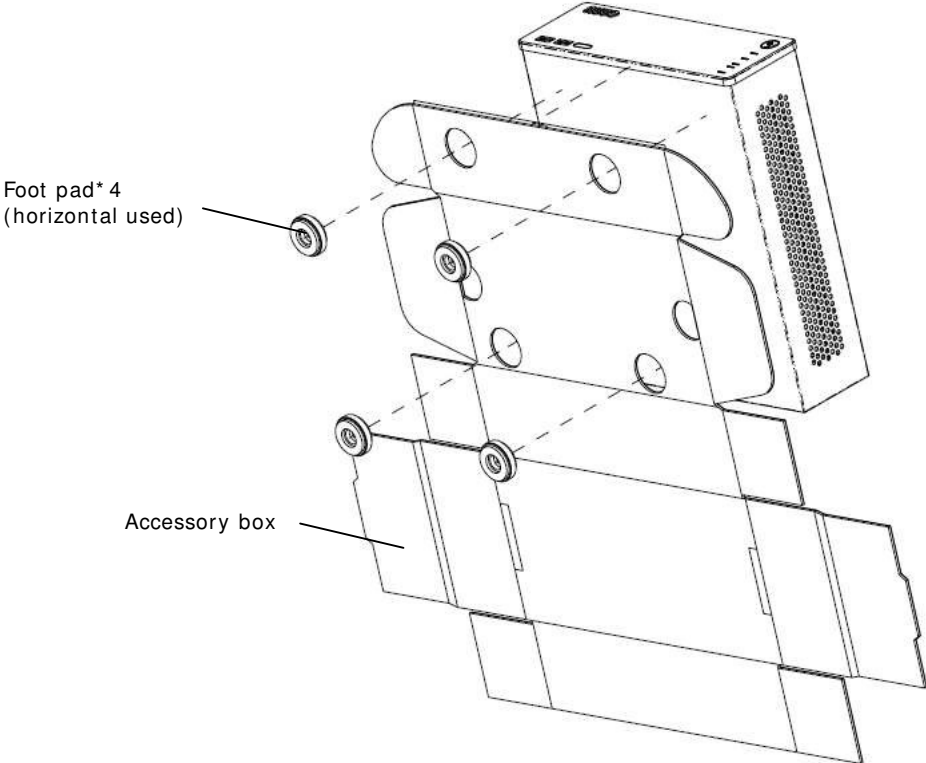

Vertical

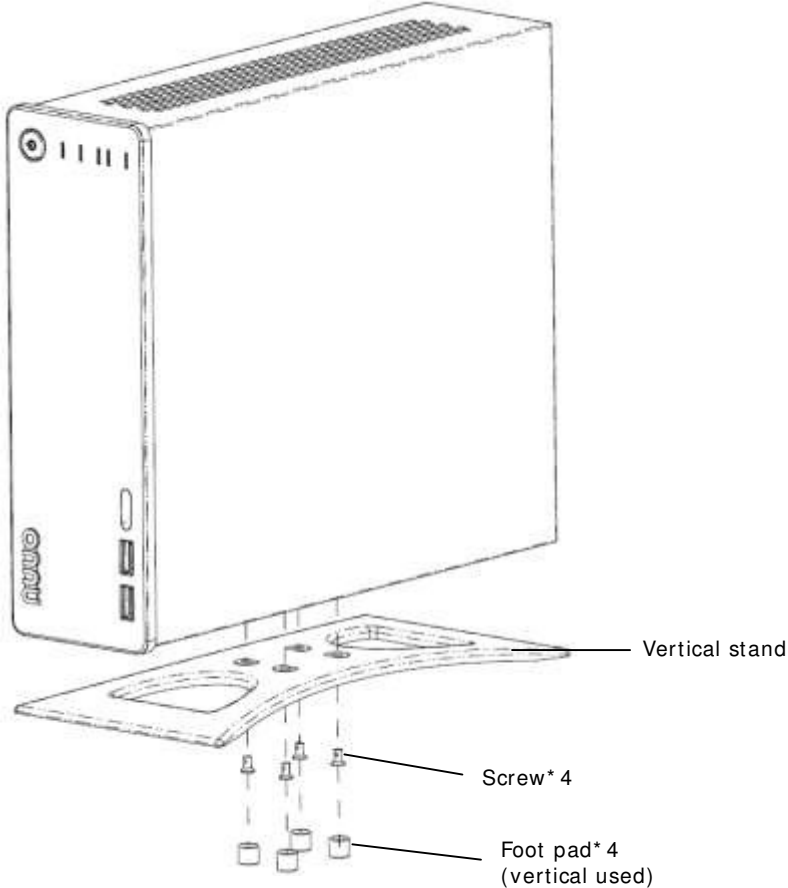

Install 3.5" HDD

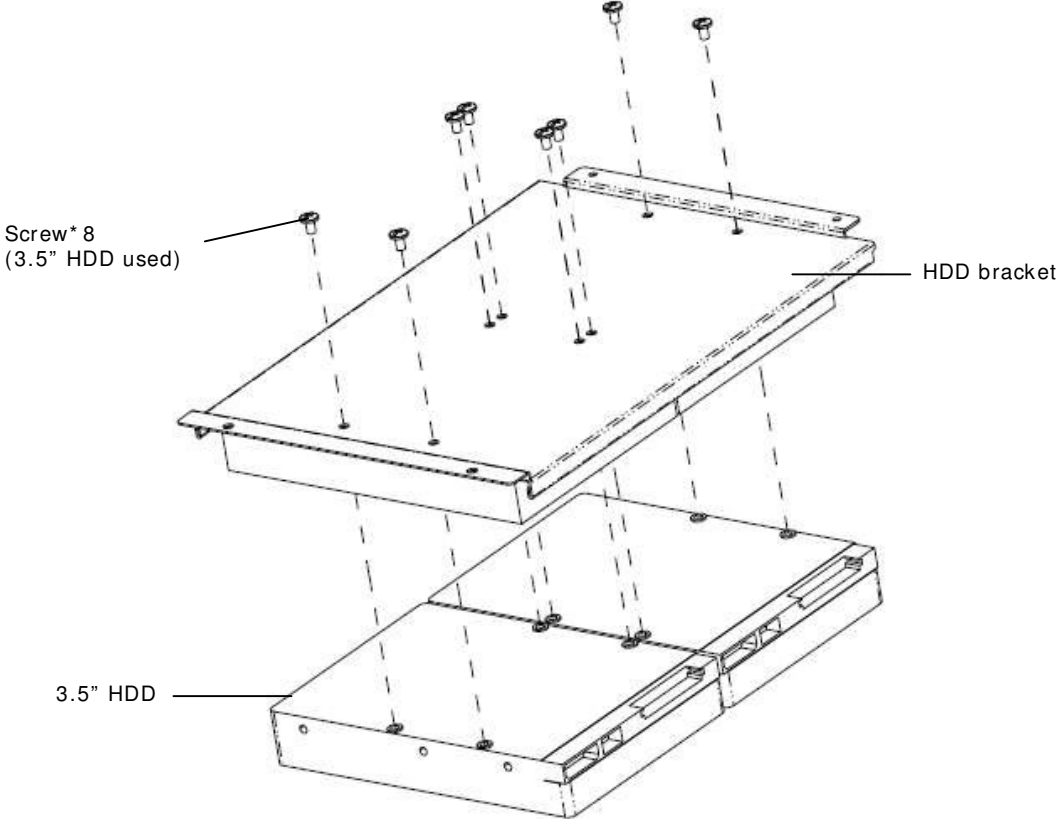

 When installing HDDs on HDD bracket, please mind your hands from scratching.

Add: B1, No.207-1, Sec.3, Beixin Rd.,Xindian Dist., New Taipei City, 231, Taiwan

Telephone: + 886-2-7739-2260

<http://www.nuuo.com/ehelpdesk.php>

